

TrackTrim®  
With Manual Curtain Track

FLAT END TTFE35F

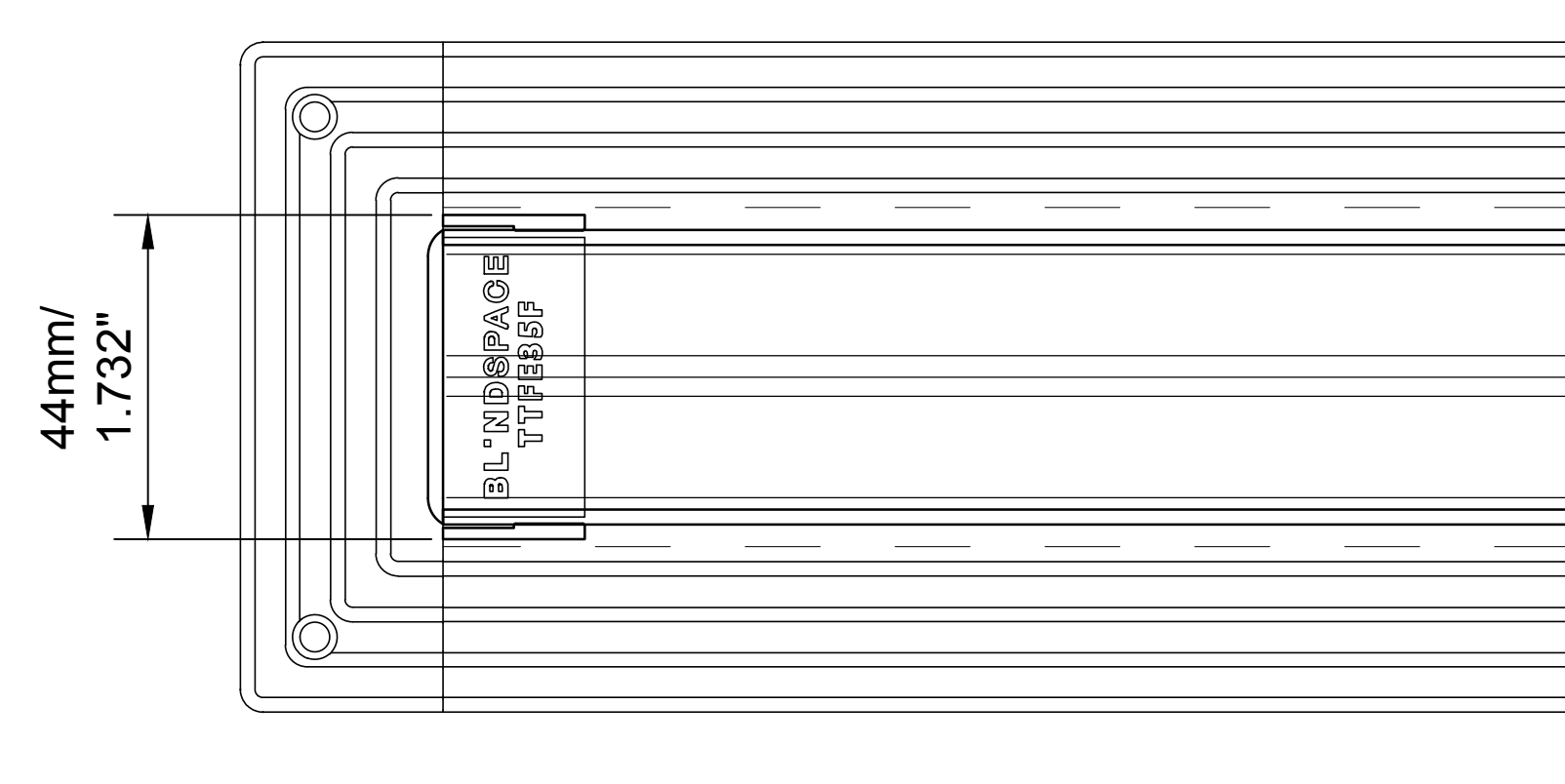

TRACK PROFILE TT1F/TT2F

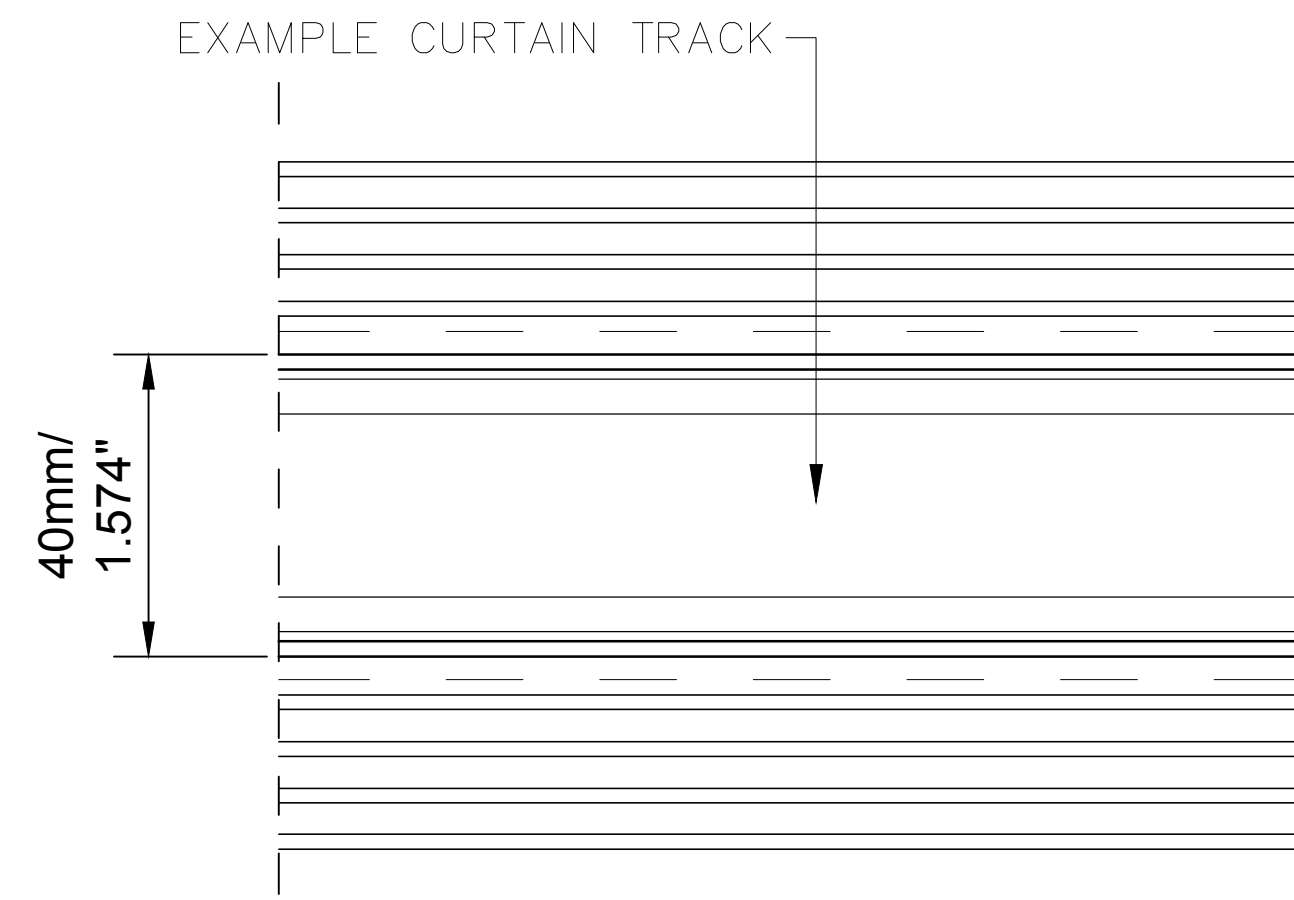

FLAT END TTFE35F

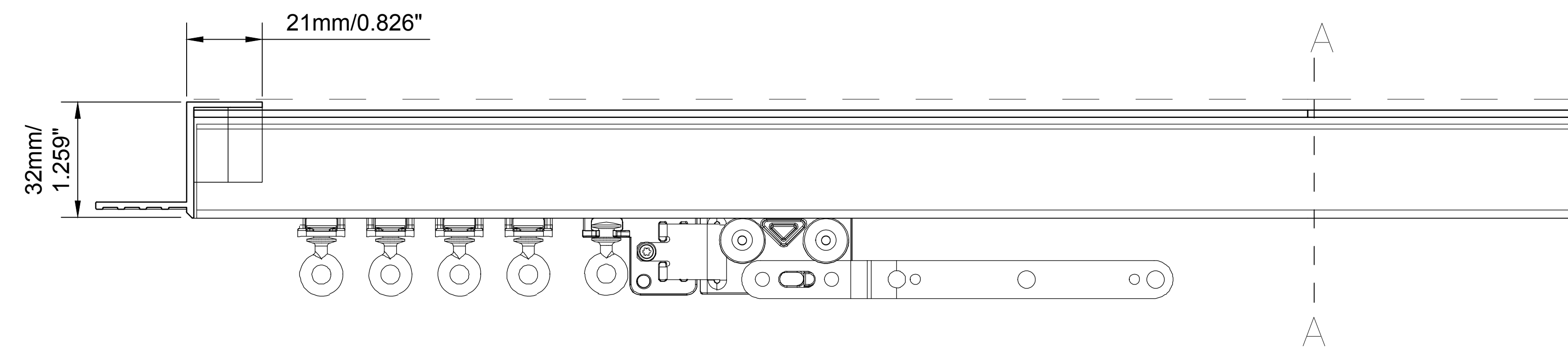
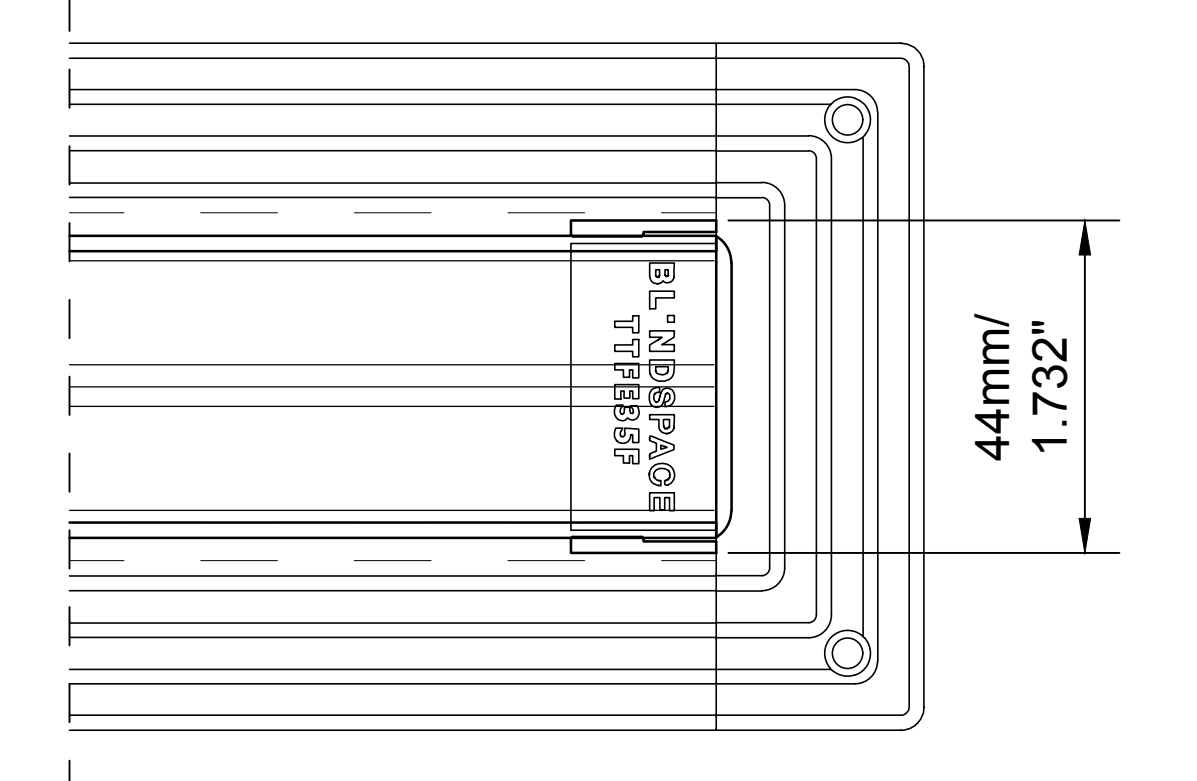

SECTION A-A TT1F PROFILE

SCALE 2:1

TT1F - Track with Screw Channel, possible Screw-Through Fixing

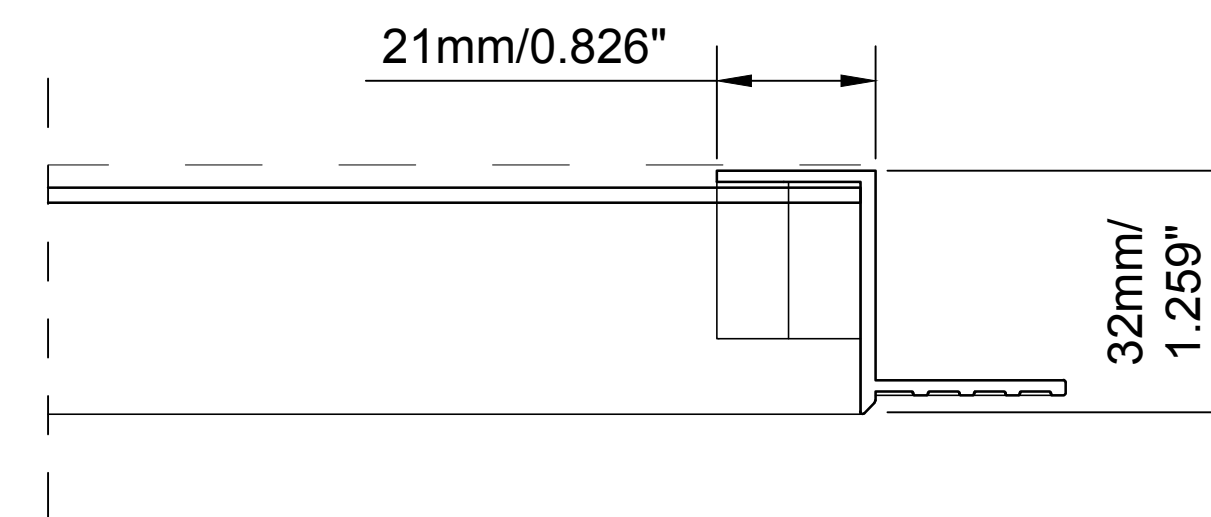

SECTION A-A TT2F PROFILE (OPTIONAL)

SCALE 2:1

TT2F - Track for Screw-Through Fixing

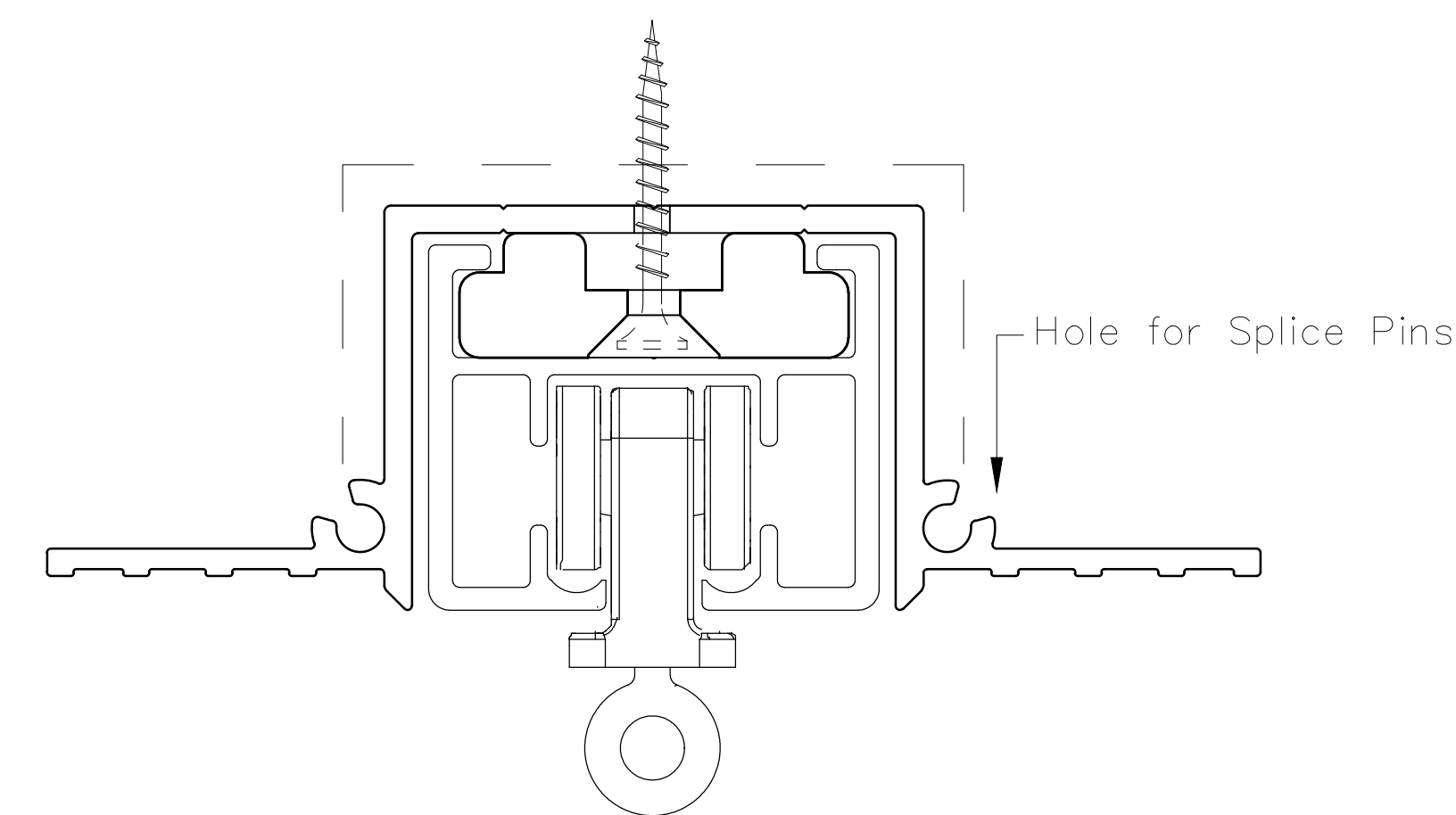
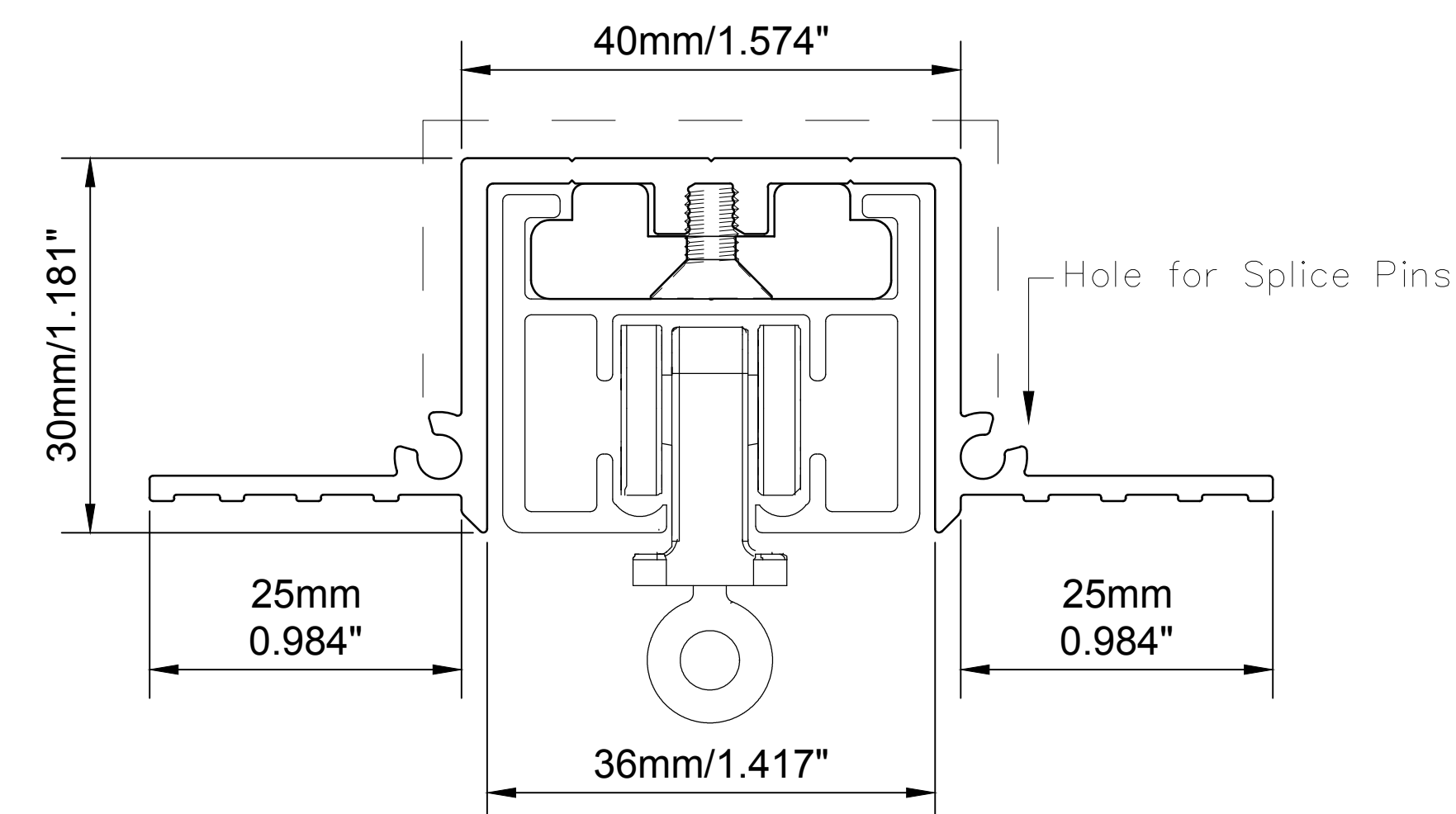

SCALE: 1:1

Light & Shade  
SOLUTIONS

BY: LIGHT AND SHADE SOLUTIONS  
LIGHTANDSHADESOLUTIONS.NET  
BRIAN TONOLE  
OFFICE: 1-877-587-4233  
EMAIL: SALES@LIGHTANDSHADESOLUTIONS.NET

PRODUCT: TRACKTRIM WITH MANUAL ENDS

DESCRIPTION: RECESSED PROFILES TO HOUSE CURTAIN TRACKS.

MATERIAL:  
TRACK EN 6063 T6  
END SET PLA THERMOPLASTIC POLYESTER

FINISHES:  
WHITE TO BE PLASTERED IN AND DECORATED AT SITE TO MATCH CEILING

TRACK LENGTH:  
2000MM  
CUT TO SIZE FOR SHORTER LENGTHS.  
SPliced TOGETHER FOR LONGER LENGTHS.

INSTALLATION:  
TRACKS TO BE FIXED WITH COUNTERSINK SCREWS EVERY 200MM THROUGH BACK (AND BOTH FLANGES WHEN AVAILABLE) INTO APPROPRIATE BACKING. SCRM TAPE TO BE USED ON FLANGES. FINISHED PLASTER LEVEL TO BE FLUSH WITH CHAMFERED EDGE. ALLOW 3MM RECESS SPACE FOR EASE OF INSTALLATION. SHOWN IN DASH LINE AROUND TRACKS.

ITEM NAMES:  
BLUNDSPACE TRACKTRIM WITH MANUAL CURTAIN TRACK  
TRACKS: TT1F/TT2F  
END-SETS: TTFESF/TT2ES  
EXAMPLE: TT1F WITH TTFESF

SHEET #:  
T11.0